

**ZMP: HIGH PRESSURE LENTICULAR FILTER HOUSING!**

ZMP series has been designed to propose a product suitable for being used in Food & Beverage market and in general in sanitary industry. The characteristics and building flexibility make the ZMP series the optimal proposal for price and quality of product.

**DESIGN**

Filter ZMP has been designed in accordance to EN 13445 rule. Dimensions 12" and 16", flat connection (standard) or bayonet, bowls for 1/2/3/4 modules.

Filter housing design pressure range:  $-1 \div 8$  bar; temperature range  $-20 \div 150^{\circ}\text{C}$ . ZMP filter housing design is for not dangerous fluid and could be supplied in II and III CE 97/23 PED category basing on filter dimension.

The filter housing standard external surface finishing is mechanical polishing, same solution is for internal surface finishing with a roughness of  $\text{RA} < 0.8\mu$ . On request it's possible also also electro-polishing as surface finishing.

**CONSTRUCTION MATERIALS**

ZMP wetted parts, are built in Stainless Steel AISI 316L. Polypropylene material is used for Tighten Nut of internal set of flat version.

**GASKETS MATERIALS**

ZMP filter housings are extremely adaptable to several fluids. Gaskets can be supplied in many kind of materials depending on the application. The standard gaskets are in Silicone FDA Approved.

**ATEX**

ZMP filter housing is ATEX certified. It doesn't require additional certification costs. The user manual shows all the ATEX rules information.

**CERTIFICATES**

As etched on the data label, ZMP filter housings series have been designed under CE 97/23 PED. Alteco, on demand, is able to supply all the additional documentation you require.

**FLANGED BENDS**

If you choose heavy connections (e.g. FLANGES ANSI 150lb), bends are fixed on the baseplate by a flanged closure system. in this way the filter housing bends are exposed to stress caused by the filtration plant, this system closure allows more resistance.

**VENTS, DRAINS, IN/OUT CONNECTIONS FLEXIBILITY**

Vents, drains and IN/OUT connections are fully adaptable. A wide range of vents, drains and IN/OUT connections can satisfy all your needs avoiding any kind of adapters. The standard connection for Vent and Drains of the ZMP series is Clamp 1.5", on demand it's possible to apply also a DIN 11851 DN25 connection.



AVT <sup>®</sup> FILTER HOUSING	
PART NUMBER	ZMP
MODEL	ZMP
TYPE	
DIAMETER (inch) x NO. MODULES	"N"
CATEGORY CE 97/23	"M"
VOLUME LITRES (V)	"V"
PRESSURE(PS) min-max at TS= $-20 \div 40^{\circ}\text{C}$ bar	$-1 \div 8$ ⚠
PRESSURE(PS) min-max at TS= $-20 \div 150^{\circ}\text{C}$ bar	$-1 \div 4$ ⚠
TEST PRESSURE(PT) bar	16
DESIGN TEMPERATURE (TS) min-max	$-20 \div 150^{\circ}\text{C}$
FLUID GROUP (PED CE 97/23)	2
PHISICAL STATE	LIQUID / GAS
VESSEL MATERIAL	316L / 1.4404
YEAR OF MANUFACTURE	
VESSEL NUMBER	
ATEX CLASSIFICATION	II 2 GD IIC
ATEX CERTIFICATION	04.01 EX.02-X
⚠ SEE USER MANUAL FOR MAX WORKING PRESSURE WITH NOT DANGEROUS GAS IN ACCORDANCE TO CE 97/23	

**DATA LABEL EXAMPLE**

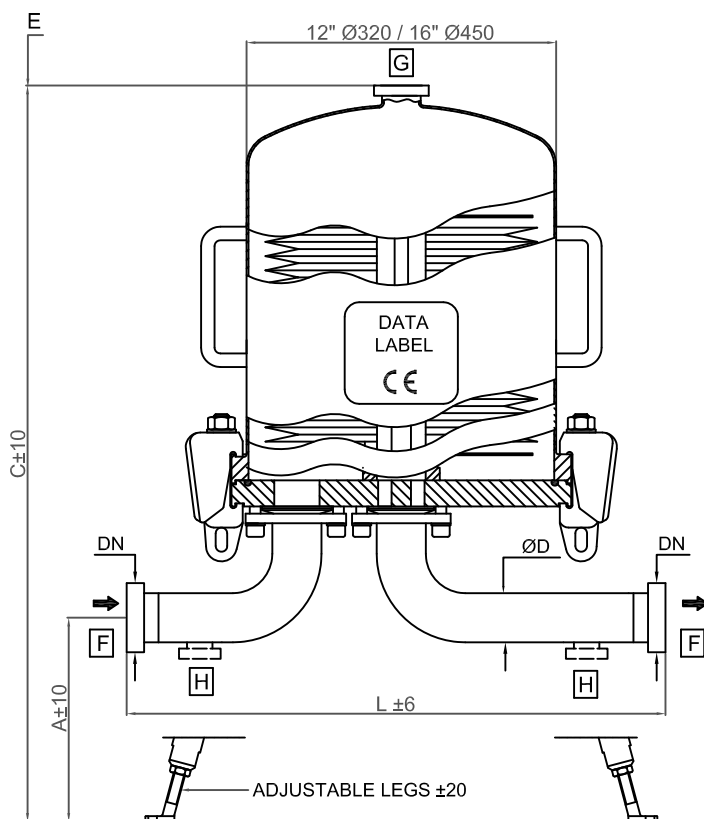
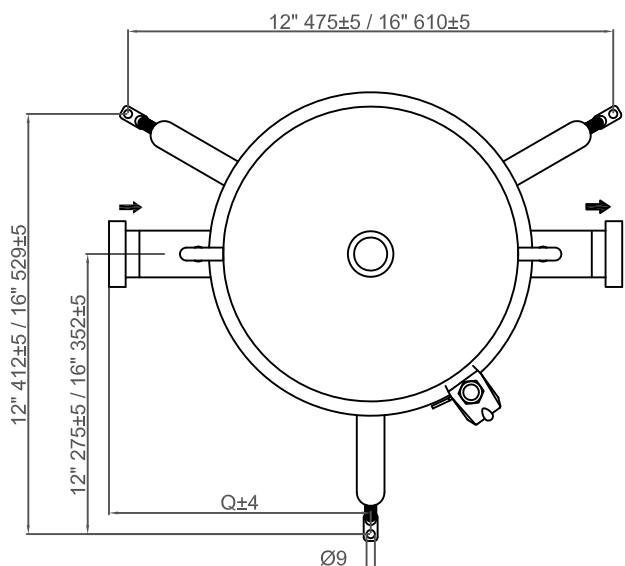

**DIMENSIONAL DATA**

	12"				16"			
	ZMP 121	ZMP 122	ZMP 123	ZMP 124	ZMP 161	ZMP 162	ZMP 163	ZMP 164
<b>MODEL</b>	ZMP 121	ZMP 122	ZMP 123	ZMP 124	ZMP 161	ZMP 162	ZMP 163	ZMP 164
<b>MODULES DIAMETER x NUMBER (N)</b>	12"x1	12"x2	12"x3	12"x4	16"x1	16"x2	16"x3	16"x4
<b>PED CATEGORY (M)</b>	II	II	II	II	II	II	III	III
<b>C mm</b>	970	1240	1520	1820	970	1240	1540	1840
<b>E mm</b>	460	730	1010	1310	460	730	1030	1330
<b>TOTAL VESSEL VOLUME litres (V)</b>	32	53	74	96	63	105	147	191
<b>BOWL WEIGHT kg</b>	11	16	20	25	21	30	40	50
<b>TOTAL NET WEIGHT kg</b>	44	50	58	63	75	86	99	111
<b>PACKAGING SIZE 12" CM 50x51x</b>	90	115	140	165	-	-	-	-
<b>PACKAGING SIZE 16" CM 63x64x</b>	-	-	-	-	100	125	150	175
<b>TOTAL WEIGHT PACKED kg</b>	49	56	65	70	81	93	107	119

IF VENT=FLANGE C=C+30 E=E+30

**PART NUMBERS**

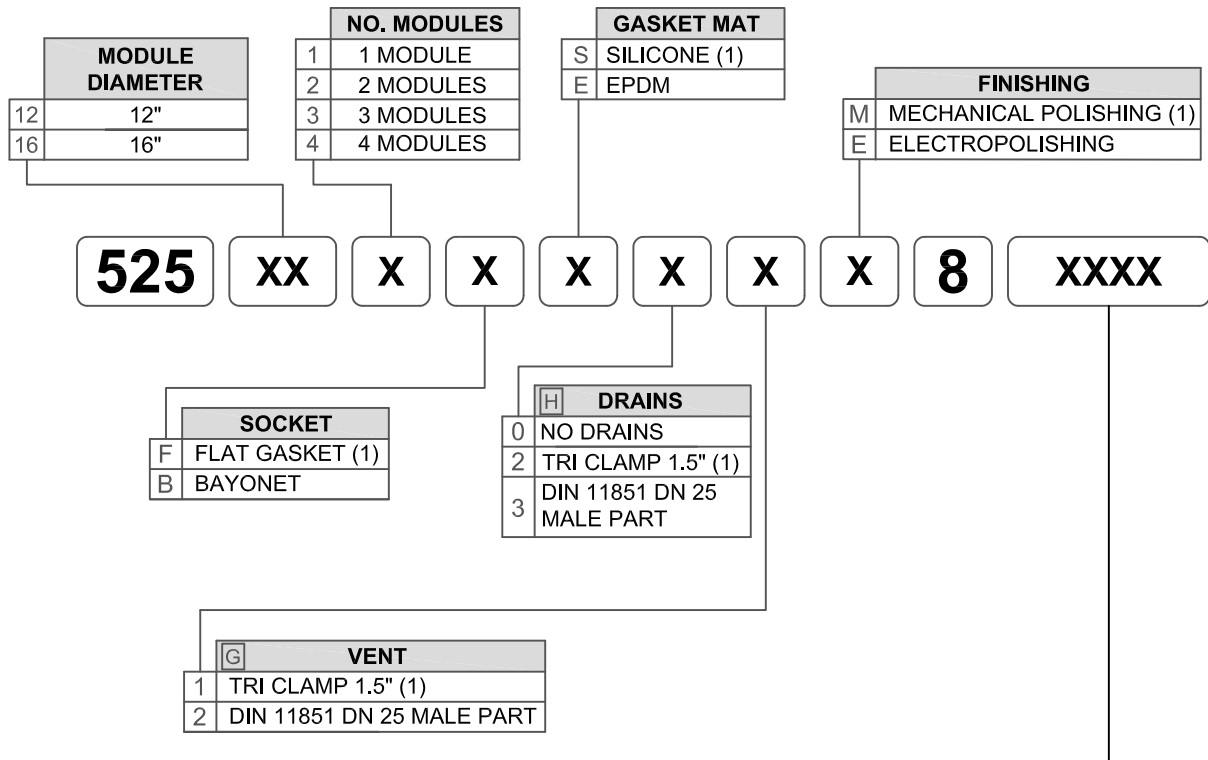

INLET - OUTLET CONNECTIONS		DN	ØD	A	12"		16"		12"		16"	
					Q	L	Q	L	Q	L	Q	L
[F] WELD (1) ASME BPE	W038	1.5"	38.1x1.65	373	260	480	300	585	185	405	225	510
	W051	2.0"	50.8x1.65	345	280	505	320	605	213	438	253	538
[F] DIN 11851 (1) MALE PART	D040	40	38.1	373	293	546	333	651	218	471	258	576
	D050	50	50.8	345	315	575	355	675	248	508	288	608
[F] CLAMP (1)	T015	1.5"	38.1	373	273	505	313	611	197	430	237	535
	T020	2.0"	50.8	345	293	530	333	631	226	463	266	563

WITH DRAINS                      WITHOUT DRAINS

INLET - OUTLET CONNECTIONS		DN	ØD	A	12"		16"		12"		16"	
					Q*	L*	Q*	L*	Q	L	Q	L
[F] FLANGES EN 1092	E032	32	42.4x3	363	311	561	351	671	250	501	321	641
	E040	40	48.3x3	384	320	580	360	690	260	520	330	660
[F] FLANGES ANSI 150 lb	A125	1.25"	42.4x3	363	311	561	351	671	250	501	321	641
	A150	1.5"	48.3x3	384	320	580	360	690	260	520	330	660
	A200	2.0"	48.3x3	384	320	580	360	690	260	520	330	660

WITH DRAINS                      WITHOUT DRAINS

\* WITH FLANGES DRAINS ADD. 40mm TO "L" AND "Q" DIMENSION

(1) MEANS STANDARD VERSION

**ACCESSORIES FOR ZMP RANGE (12 - 16 CARTRIDGES)**

1 SANITARY VALVE  
601300010

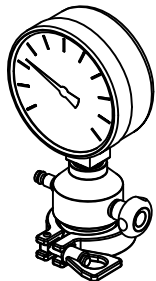

2 SANITARY VALVES  
+ SIGHT GLASS  
601310010

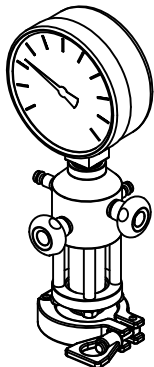

1 BALL VALVE  
601700010

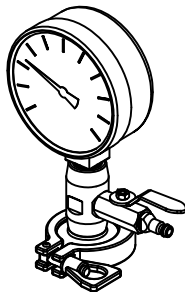

2 BALL VALVES  
+ SIGHT GLASS  
601719010

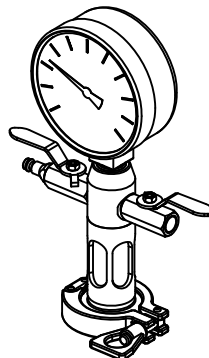

1 SANITARY VALVE  
DIAPHRAGM PRESS. GAUGE  
601349010

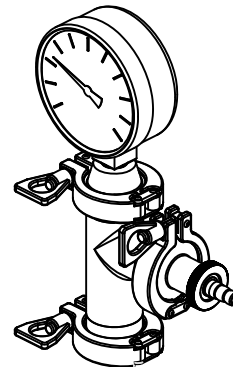

BUTTERFLY VALVE

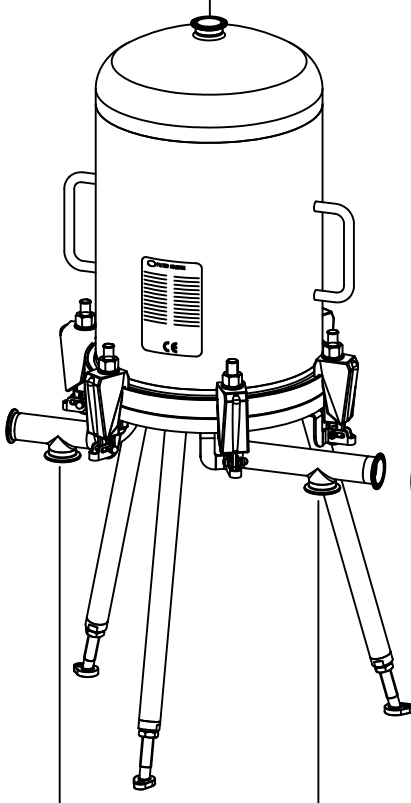
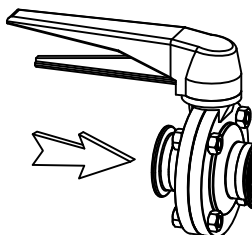

BUTTERFLY VALVE

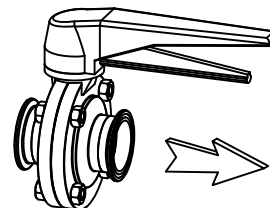

BUTTERFLY VALVE  
602320150

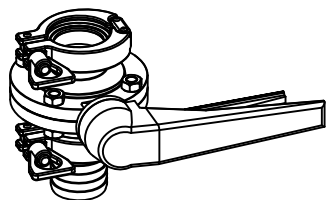

BALL VALVE  
602300150

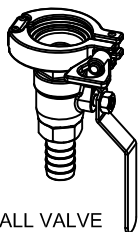

SAMPLING TEST  
602310150



ANGLE VALVE + SAMPLING  
20087

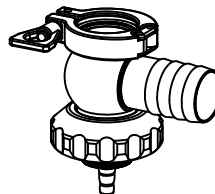

ANGLE VALVE  
20085

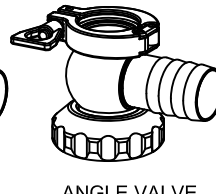

**FLAT GASKET**

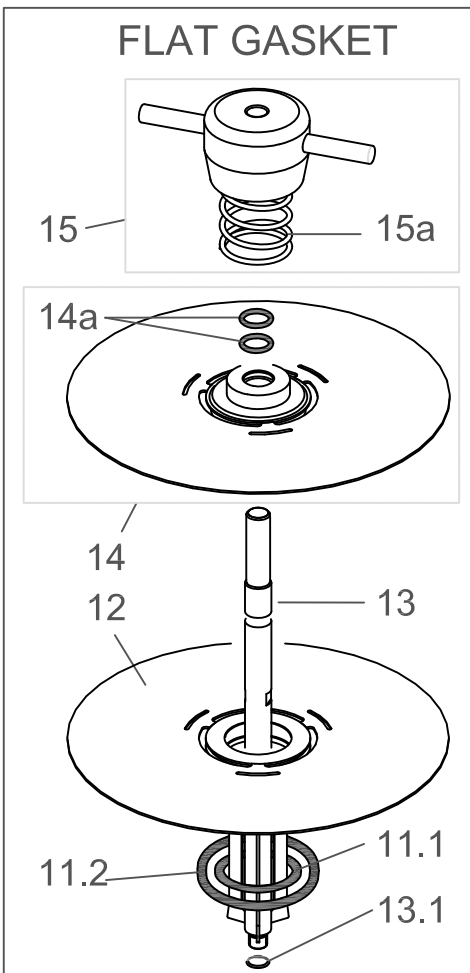

**BAYONET**

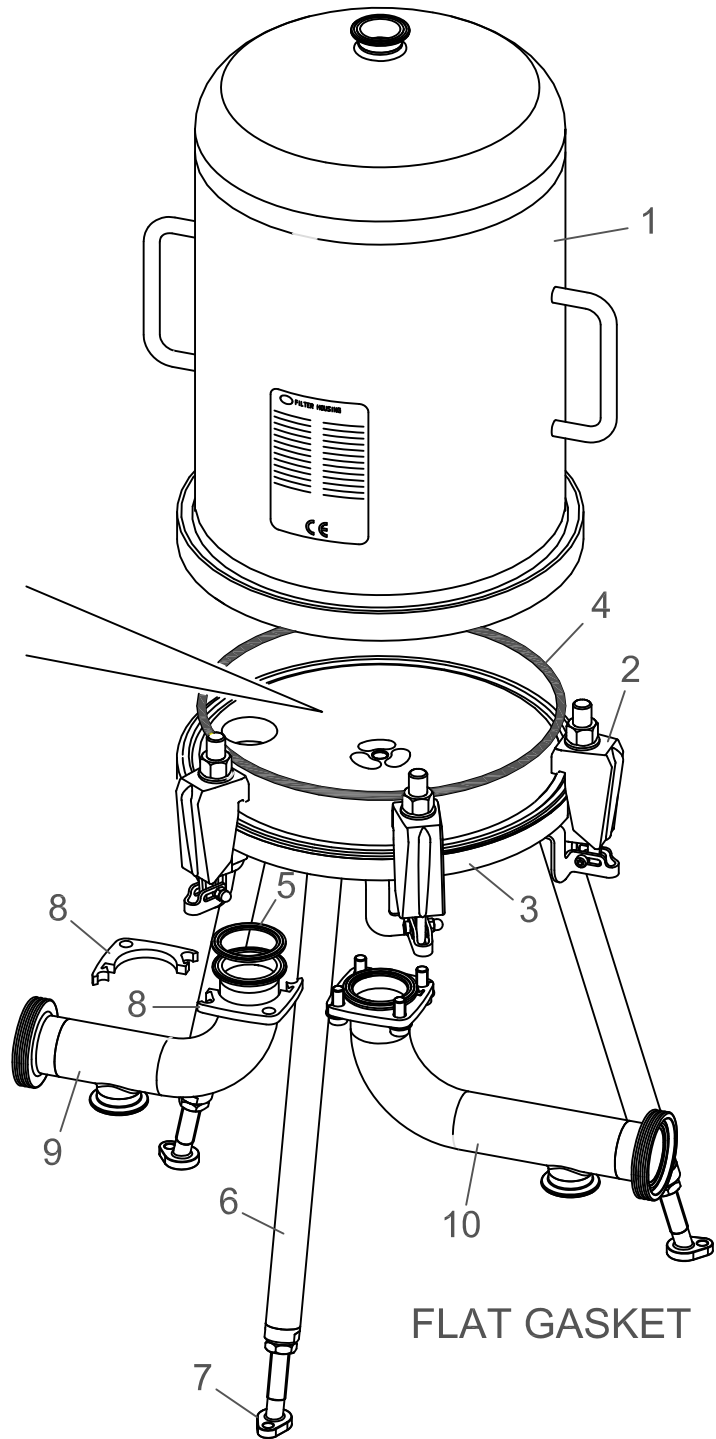
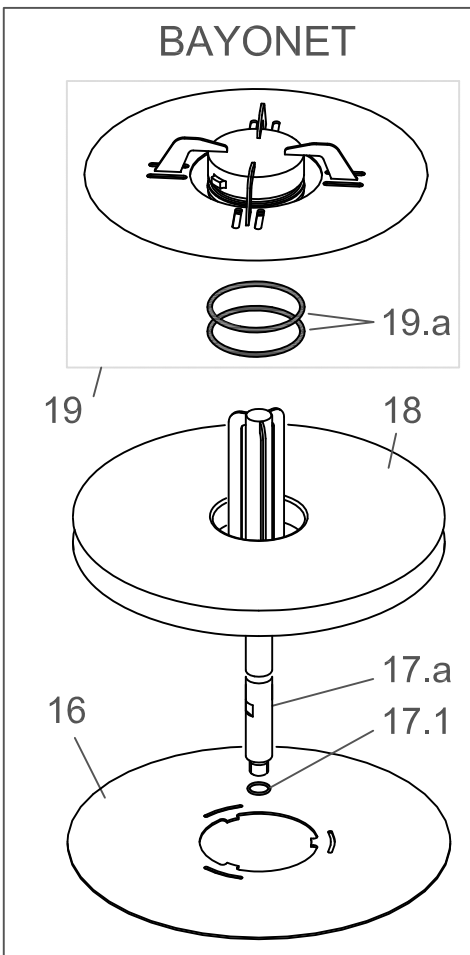

**FLAT GASKET**

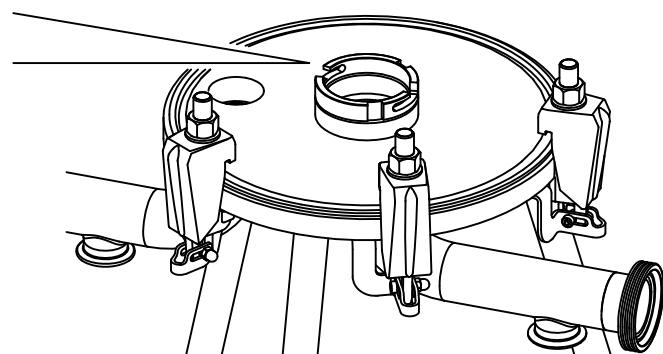

**BAYONET**

POSITION	DESCRIPTION	MATERIAL	PART. NO. 12"	PART. NO. 16"	Q.TY
1	HOUSING BOWL	AISI 316L	--	--	1
2	2.a	BOLT CLAMP M16	AISI 316Ti	1812C	5
	2.b	BOLT CLAMP M16	AISI 316Ti	--	8
3	PLATE	AISI 316L	20186	20187	1
4	4.a	O-RING ø7.00 ID=304.1	SILICONE*	80744S	1
	4.b	O-RING ø7.00 ID=443.4	SILICONE*	--	1
5	GASKET CLAMP 2"	PTFE	80022P	80022P	2
6	LEG	AISI 304	1578	1578	3
7	FOOT	AISI 304	1957	1957	3
8	BEND FLANGE	AISI 304	1563	1563	3
9	INLET BEND	AISI 316L	--	--	1
10	OUTLET BEND	AISI 316L	--	--	1
11	11.1	O-RING ø5.34 ID=53.34	FEP	84727P	1
	11.2	O-RING ø5.34 ID=69.22	FEP	84726P	1
12	LOWER PROTECTION PLATE	AISI 316L	84707	84725	1
13	13.1	O-RING ø1.78 ID=14	PTFE	81036P	1
	13.a	CENTER POST 1 MODULE	AISI 316L	20025	1
	13.b	CENTER POST 2 MODULE	AISI 316L	20026	1
	13.c	CENTER POST 3 MODULE	AISI 316L	20027	1
14	14	UPPER PLATE WITH O-RING	AISI 316L	20145	1
	14.a	O-RING ø3.53 ID=18.64	FEP	80102P	2
15	15	PP TIGHTEN NUT WITH SPRING	--	81080	1
	15.a	SPRING	AISI 316L	1543	1
16	LOWER PROTECTION PLATE	AISI 316L	20121	20123	1
17	17	O-RING ø1.78 ID=14	PTFE	81036P	1
	17.a	CENTER POST 3 - 4 MODULES	AISI 316L	20193	1
18	18.a	INTERMEDIATE PLATE FOR 2 MODULES	AISI 316L	20351	1
	18.b	INTERMEDIATE PLATE FOR 3 MODULES	AISI 316L	20351	2
	18.c	INTERMEDIATE PLATE FOR 4 MODULES	AISI 316L	20351	3
19	19	UPPER PROTECTION PLATE	AISI 316L	20138	1
	19.a	O-RING ø3.53 ID=66.68	SILICONE*	80123S	2

\* ASK FOR AVAILABLE MATERIALS

\*\* THE PART NUMBER OF INLET-OUTLET BENDS DEPEND ON THE FILTER HOUSING PART NUMBER